

Elyon Divine Components Pvt.Ltd

(Formerly Known as Divine Toolings)

House of Precision Moulds & Components

ENGINEERING DESIGN CENTER

TOOL MANUFACTURING

INJECTION MOLDING

CRITICAL ASSEMBLIES

An ISO 9001:2015 & IATF 16949:2016 certified Companies



Plant I

Address:- J 259, MIDC Bhosari, Pune 411026

Elyon Divine Components Pvt.Ltd

ELYON DIVINE
COMPONENTS PVT. LTD.
Plot No. 08, Block: F-II,
MIDC, Pimpri, Pune 411 018
GST No: 27AAFCE2532D1Z2



Plant II

Address:- F/2- Plot No.8, MIDC, Pimpri, Pune 411018



Plant III

Address:- E12-(7), MIDC, Bhosari, Pune 411026

Contents:

- **About company**
- **Milestones**
- **Valuable customers**
- **Organization structure**
- **Plant facilities & Inspection facilities**
- **Product Gallery**
- **Machine Details**
- **Design & Development**
- **Tool Maintenance**
- **Achievements**

About Company:

***Elyon Divine Components Pvt Ltd**, a trusted name in Tool design, Tool Manufacturing & Injection Molding. This is managed by a highly competent and experienced engineers and technicians in the field of polymer technology as well as Tool & Die Engineering. The facility is equipped with the most advanced state-of-the-art equipments and operated by professional technicians.*

***Elyon Divine Components Pvt Ltd'** constant quest for excellence and a will to scale new heights has made it a name to reckon with. Our Specialty to develop new Toolings (with our design & development Department backed by Team of Professional Engineers) differentiates us from other molders and mould manufacturers. We are also capable to supply high precision injection molded parts up to 1000 tones.*

***Elyon Divine Components Pvt Ltd'** products are inspected at every stage of production to maintain the best quality consistently. We understand the importance of quality and believe in it as our best salesman.*

Milestones

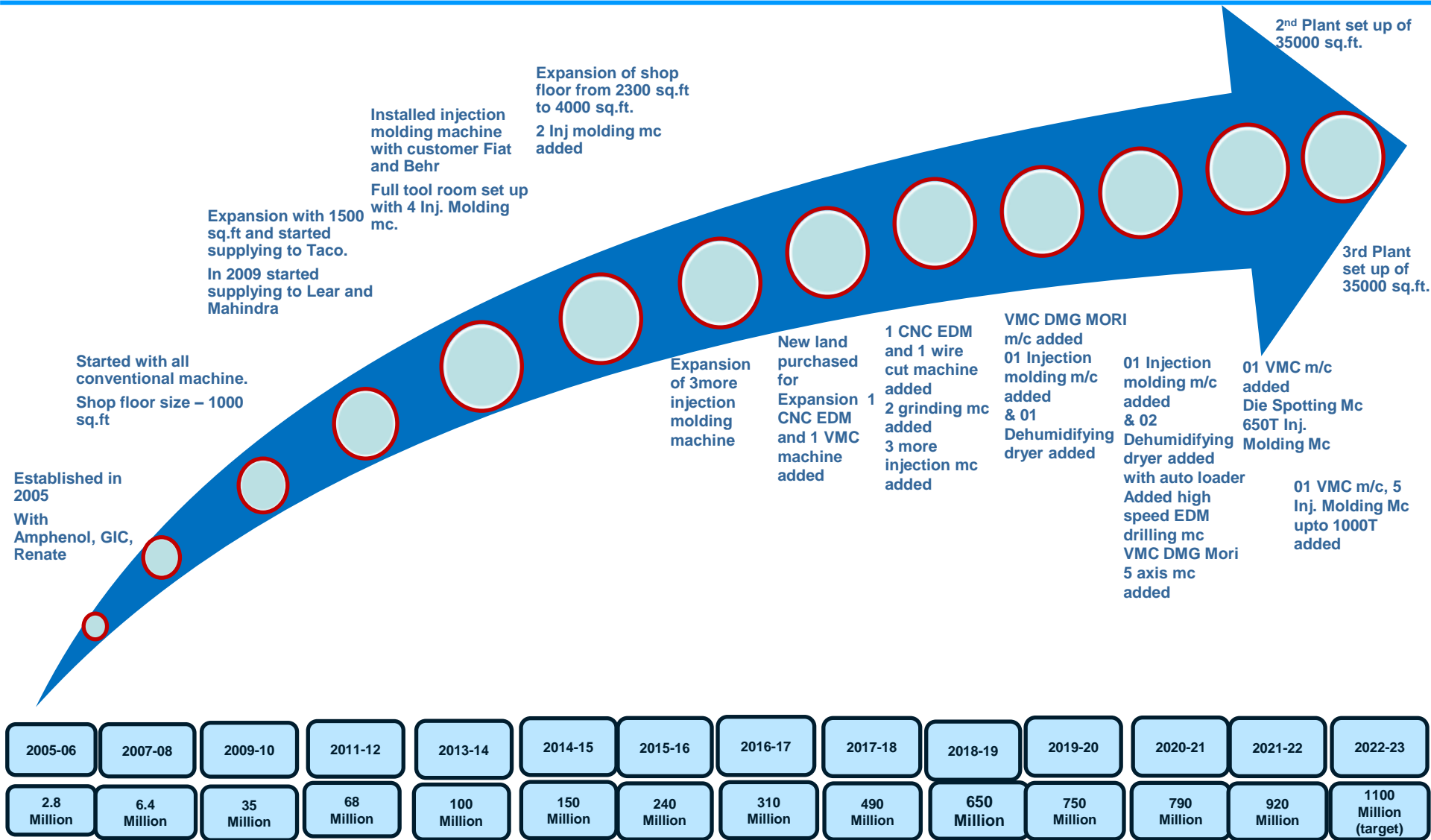

Our Valuable Customers



samvardhana
motherson



International Automotive Components



SANDEN VIKAS (INDIA) LTD.



PLASTIC OMNIUM



Air International
Thermal Systems
空调国际热能系统



AUTOCOMP SYSTEMS LTD



DENSO



BHTC



Our Valuable End user Customers



HONDA



SUZUKI

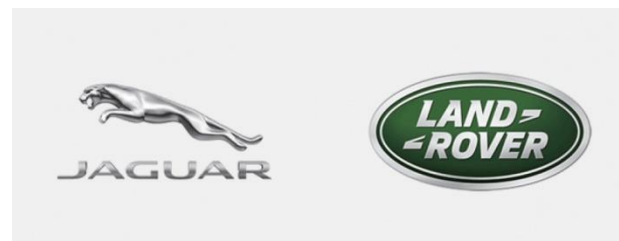

Organization chart



ELYON DIVINE COMPONENTS PVT.LTD

ORGANISATION CHART

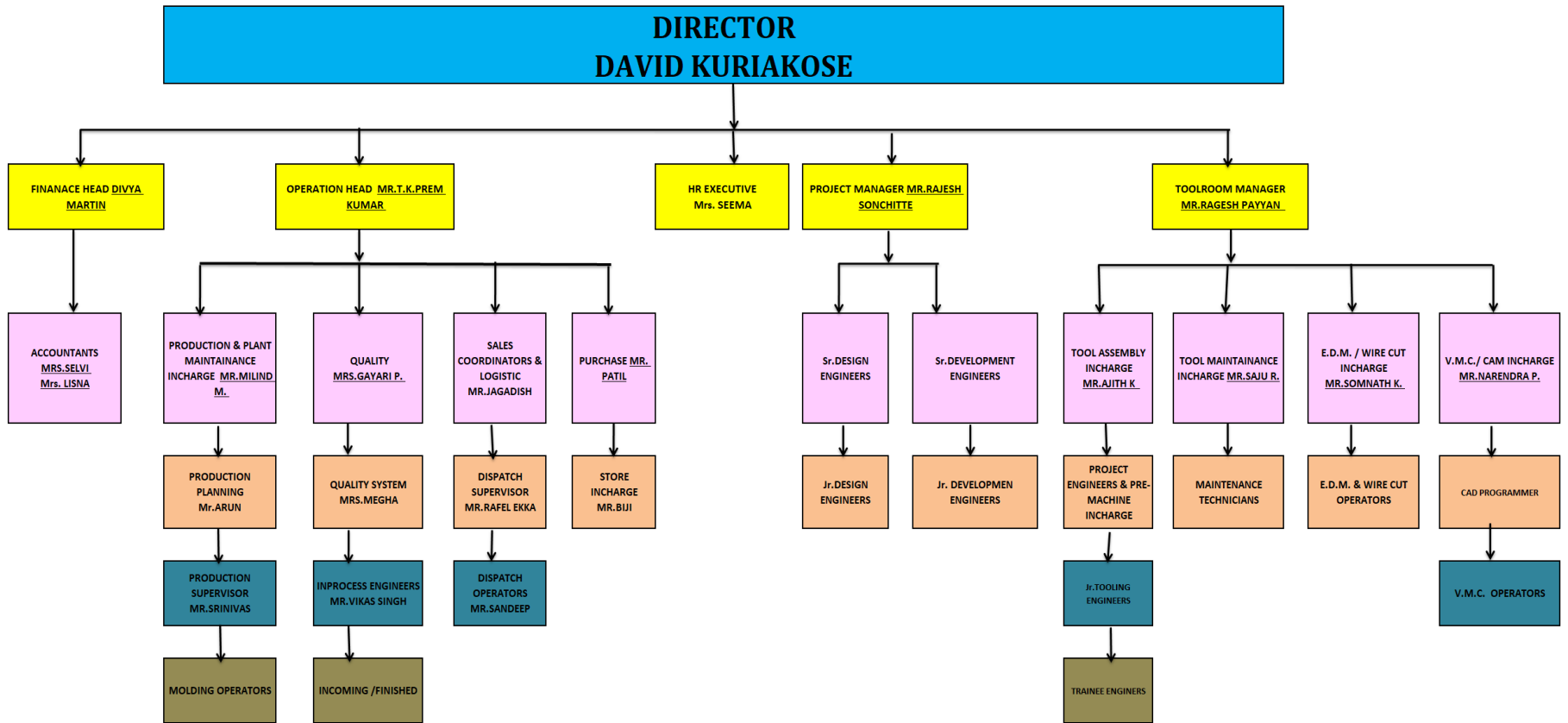

Man power Details

Total Man Power – 300 Nos

	Manager and Above	Asst. Manager	Engineers	Skilled	Semi Skilled
Tool Room	2	1	16	29	10
Molding	3	3	12	28	9

Our Vision and Mission

VISION

- *To be consistently recognized by our:*
 - *Customers*
 - *Employees*
 - *Suppliers*
 - *The communities where we do the business as a leader & the company of first choice*

Mission

- *Exceed our customer's need & expectation by:*
 - *Delivering the Highest quality products & service*
 - *Providing low cost & high value added solutions*
 - *Continually Improving our operating efficiency*
 - *Conducting our business with Integrity*
- *Providing employees, our most valuable resources with an environment that:*
 - *Treats all individuals with Dignity & Respect*
 - *Allows everyone to reach their full potential*
 - *Encourages inclusion & active participation*

Certifications

ZERTIFIKAT ♦ CERTIFICATE ♦ 合格証書 ♦ CERTIFICADO ♦ CERTIFICAT



CERTIFICATE

The Certification Body
of TUV SUD South Asia Private Limited
certifies that

DIVINE TOOLINGS
House of Precisions moulds & molded components,
J259, MIDC, Bhosari, Pune – 411026, India

has implemented Quality Management System
in accordance with ISO 9001:2015
for the scope of

**Manufacturing of Moulds & Injection moulding of
plastic parts and Assemblies**

The certificate is valid from 2022-03-04 until 2025-03-03
Subject to successful completion of annual periodic audits
The present status of this certificate can be obtained through TUV SUD website by scanning below QR code and by
entering the certificate number (without spaces) on web page. Further clarifications regarding the status & scope of
this certificate may be obtained by consulting the certification body at info.in@tvsud.com

Certificate Registration No. 99 100 19667
Date of Initial certification: 2019-03-26
Issue Date: 2022-03-21 Rev. 00

Rahul Kale
Head of Certification Body
of TUV SUD South Asia Private Limited,
Mumbai
Member of TUV SUD Group



TUV SUD South Asia Pvt. Ltd. • TUV SUD House • Saki Naka • Andheri (East) • Mumbai – 400072 • Maharashtra • India TUV®

Divine_ISO 9001:2015

Certifications



Divine_IATF 16949 : 2016



Elyon Divine_IATF 16949 : 2016

Plant facility

Facility	Capacity/Size	Qty (Nos)
VMC DMG MORI (90P) 5 axis	Table dia : 900 mm and 1800 kg Table max load	01
VMC DMG MORI	Table size : 1100 x 700mm	02
VMC TAKUMI	Table Size: 1600 x 1300 x 650 mm	01
VMC BFW CHAKRA BMV 60	Table size: 600 x 1250mm	02
VMC BFW AGNI BMV 45	Table size : 450 x 900mm	01
VMC BFW XTRON 755/955	Table size : 900 mm x 500 mm	01
Die Spotting Machine (Shunxing) 160YC	Table Size: 1600 mm x 1300 mm	01
CNC WIRE EDM SODICK AG 600L	Table size: 600 x 400 x 350mm	01
CNC WIRE EDM SODICK AG 1600L	Table size: 1600 x 1100 x 550mm	01
CNC WIRE EDM SODICK AQ 300L	Table size: 300 x 200 x 150mm	01
CNC EDM SODICK AD 55L	Table size: 600 x 400 x 400mm	02
NC EDM WITH ORBITING CHMER	Table size : 300 x 200 x 150mm	01
NC EDM CHMER	Table size : 500 x 400 x 400mm	01
EDM Drill Machine	Table Size-400mmX300mm, Above 20mm/min	01
GRINDING MACHINE OKAMOTO	500 X 200 x 300	01
GRINDING MACHINE OKAMOTO	400 X 150 x 200	01
GRINDING MACHINE KENT	600 x 250 x200 mm	01
GRINDING MACHINE PRAGA	450 x 200 x 200 mm	02
COLOUM & KNEE TURRET MACHINES	Table size: 800 x 400 x300mm	02
RADIAL DRILLING MACHINE	Table size: 1000 x 1000 x 600 mm	01
LATHE MACHINE	-----	01
POWER SAW MACHINE	-----	01

Plant facility

Facility	Capacity/Size	Qty (Nos)	Spare capacity
Toshiba D Tech Injection molding 100T	Tie Bar Distance – 410 x410 mm	11	15%
Toshiba D Tech Injection molding 150T	Tie Bar Distance – 510 x 510 mm	12	25%
Milacron Injection Molding 150T	Tie Bar Distance – 510 x 510 mm	01	25%
FERROMATIC magna T servo Injection molding 150T	Tie Bar Distance - 510 x 510 mm	01	10%
Toshiba D Tech Injection molding 200T	Tie Bar Distance – 500 x 500 mm	01	20%
Toshiba D Tech Injection molding 250T	Tie Bar Distance – 580 x 580 mm	01	15%
Toshiba D Tech Injection molding 275T	Tie Bar Distance – 645 x 645 mm	01	15%
Thoshiba D Tech Injection molding 300T	Tie Bar Distance – 660 x 660 mm	01	20%
Thoshiba D Tech Injection molding 350T	Tie Bar Distance – 720 x 720 mm	02	20%
Thoshiba D Tech Injection molding 650T	Tie Bar Distance – 870 x 870 mm	01	10%
FERROMATIC Injection molding 650T	Tie Bar Distance – 920 x 920 mm	01	10%
FERROMATIC Injection molding 1000T	Tie Bar Distance – 1300 x 1100 mm	01	30%
NOVA SERVO Injection molding 110T	Tie Bar Distance – 430 x 430 mm	01	5%
Milacron Injection molding 180T	Tie Bar Distance – 570 x 530 mm	01	15%

Plant facility

Facility	Capacity/Size	Qty (Nos)	Spare capacity
Over head Crane	10t	01	
Over head Crane	15t	01	
Over head Crane	5 TON	02	
Over head Crane (molding)	2 TON	02	
Mold Temperature controller - (Oil MTC)	-----	05	
Hot runner Temperature controller – Hot Tip & Mold master	-----	09	
Hopper Dryer – for all machines	-----	16	
Bry-Air Honeycomb Rotor Dehumidifying dryer Model BHD 120 (120 cmh)	30 – 35 Kg / Hr	02	

FUTURE EXPANSION PLANS

2023 Plan – Tool Room

Sr. No.	Name of Machine	No. of Machines	Plan Date
1	CMM Machine (ZEISS MAKE)	01	July 2023
2	Deep Hole Gun drilling machine	01	May 2023

FUTURE EXPANSION PLANS

2023 Plan – Manufacturing

Sr. No.	Name of Machine	No. of Machines	Plan Date
1	Injection molding machine	03	April 2023
2	250T - 2K Molding Machine	01	June 2023
3	450T – 2K Molding Machine	01	July 2023

Inspection Facilities



Trimos



VMM (Video Measuring Machine)

Inspection Facilities



Specific Gravity Tester



Color Cabinet



Melt Flow Index Tester

Inspection Facilities



Gloss Meter



Blower Fan Balancing



Fan Balancing

Product Gallery- components in production



Air Intake Housing and Ducts
Customer – AITS and Behr

Product Gallery- components in production



Pull Cup for Mahindra



Switch Bezel for TML & Mahindra

Product Gallery- components in production



Radial Fan for HVAC - TML, VW, Mahindra

Product Gallery- components in production



Altroz Fan for MATS



Inlet / Outlet Tank for MATS

Product Gallery- components in production



Console part for Honda, Suzuki and Renault



Console parts for TML Q5

Product Gallery- components in production



Console part for TML Q5



Insert molding for climate control and Radiator for Mahindra and TML

Product Gallery- components in production

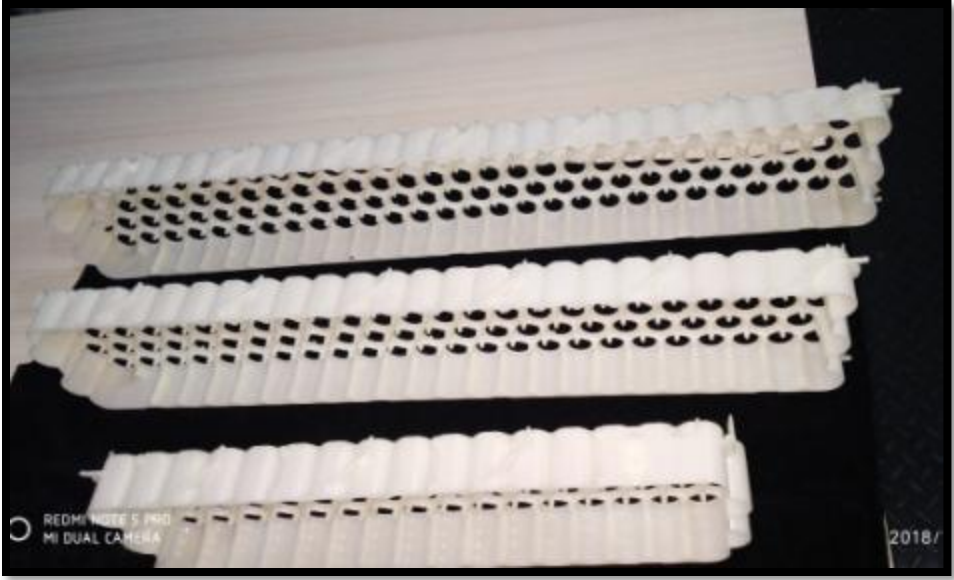
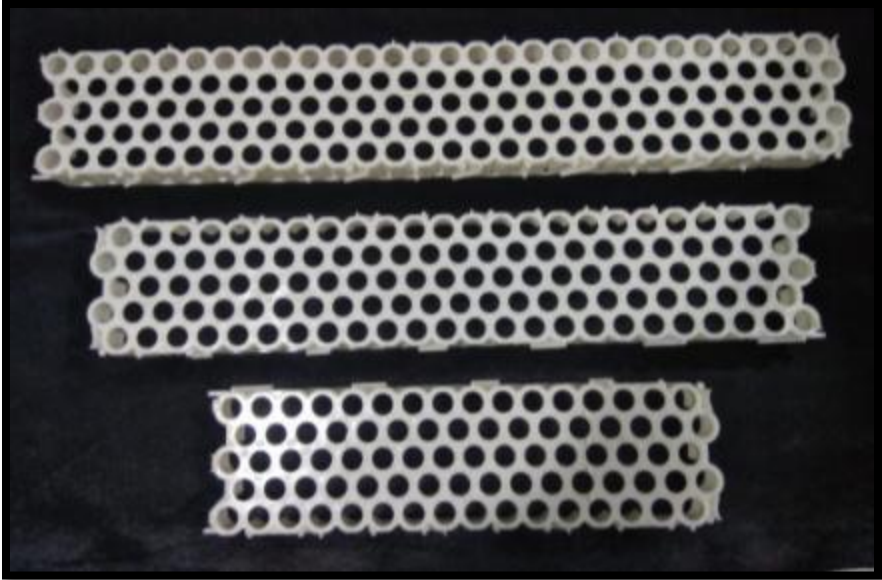

Electric car Battery carrier for JLR

Product Gallery- components in production



Ball cages part for Suzuki
and Renault

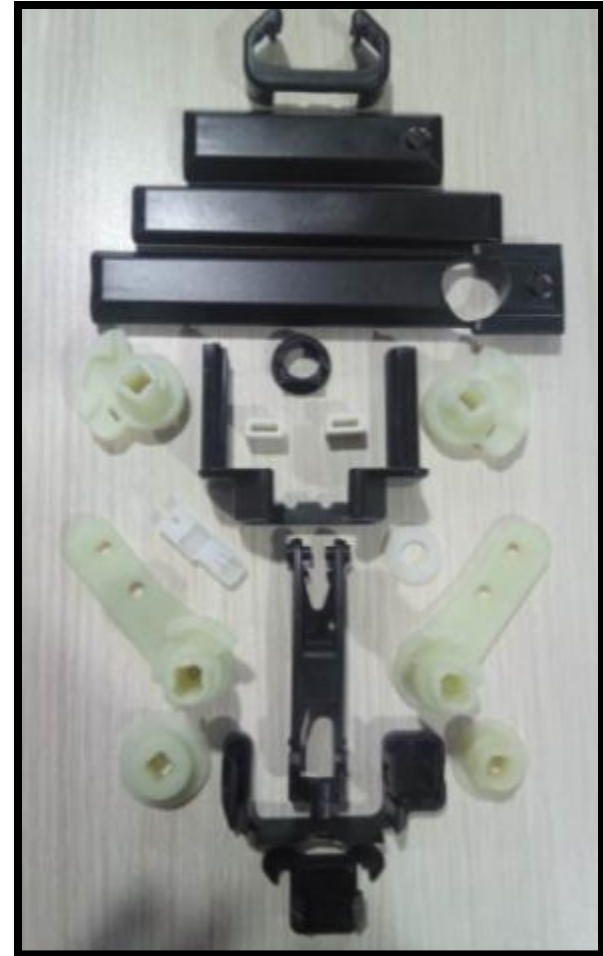

Recliner and Track parts for
Suzuki

Product Gallery- components in production



Ball Grommet
for Fiat Chrysler



Head Rest Grommet
for B515 Ford



Electrical parts for
Volvo and BHTC

Product Gallery- components in production



Air vent parts for VECV

Kinematic parts for JLR



Product Gallery- components in production



Air Bag PAB Chute channel for Mahindra

Product Gallery- components in production



Cluster for IAC

Product Gallery- components in production



Over molded Doors for
VW India, USA

Machine details



VMC DMG MORI 5 AXIS MACHINE DMU 90 P duoBLOCK

Machine details



Sodick AG 100L EDM machine

Machine details



VMC DMC 1150V MACHINE

Machine details



VMC DMG MORI 3 AXIS MACHINE

Machine details



CNC EDM Sodick
Machine



High Speed EDM Drilling
Machine

Machine details



VMC Chakra Machine



M1TR Machine



Die Spotting Machine

Machine details



CNC WIRE CUT
Sodick Machine

CNC EDM Chmer
Machine



Machine details



OKAMOTO SURFACE GRINDING (SMALL)



OKAMOTO SURFACE GRINDING (BIG)

Molding Machine details



Nova Servo molding machine 110T



Toshiba Moulding machine 150 T



Ferromatic Magna T servo molding machine 150T



Toshiba molding machine 350T

Molding shop set up



Plant I

Molding shop set up



Plant II

Design & Development



Elyon Divine Components Pvt Ltd offers the following services for Mold designing :

- **Conceptual Designing**
- **3D modeling**
- **Tool Designing**
- **Mold flow analysis**
- **Cam Programming**
- **CNC Machining**
- **Manufacturing of Tools & Dies**
- **Data Conversion**
- **Software : UG NX 9, Auto cad 10, Work Explore, Work NC**

Mould Flow Analysis- Fill time Animation

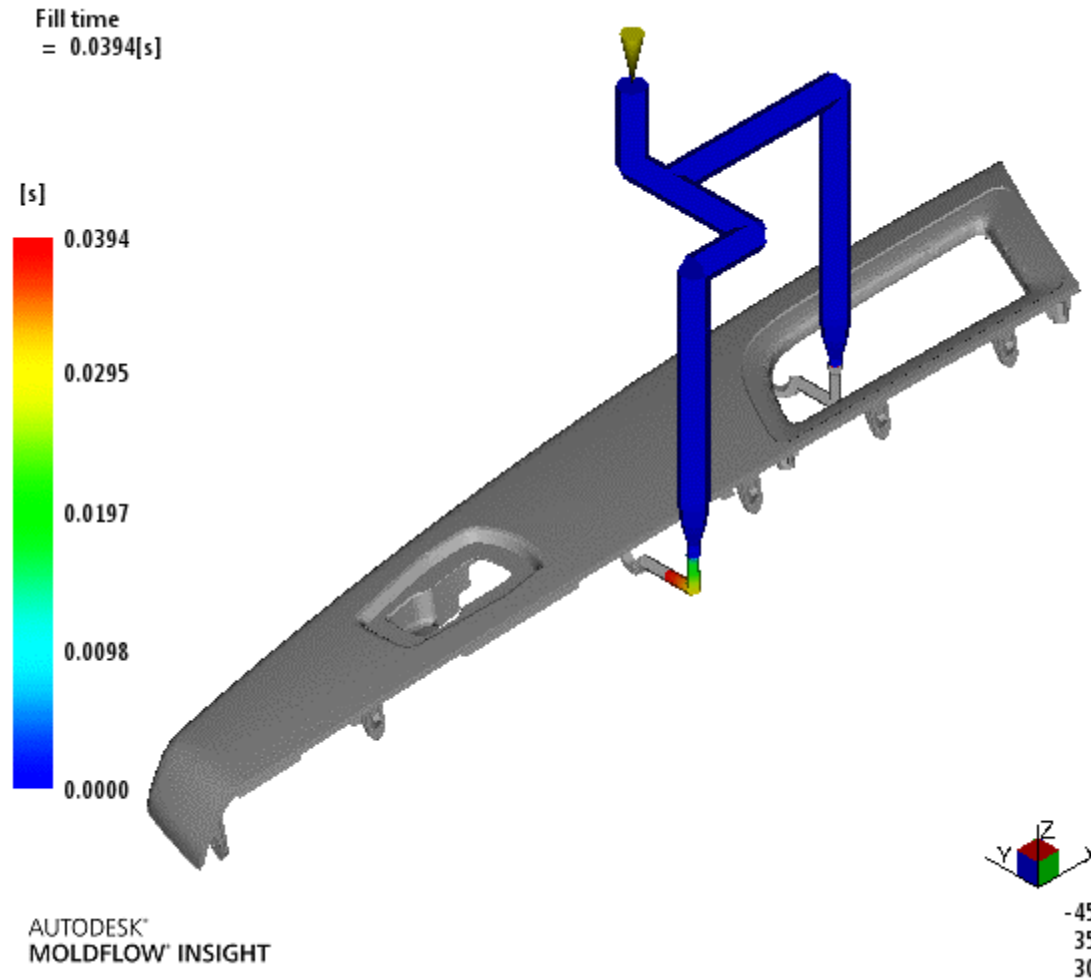

Comments: Animation Is Showing The Flow Path Of Molten Material.

Mould Flow Analysis- Fill time Animation

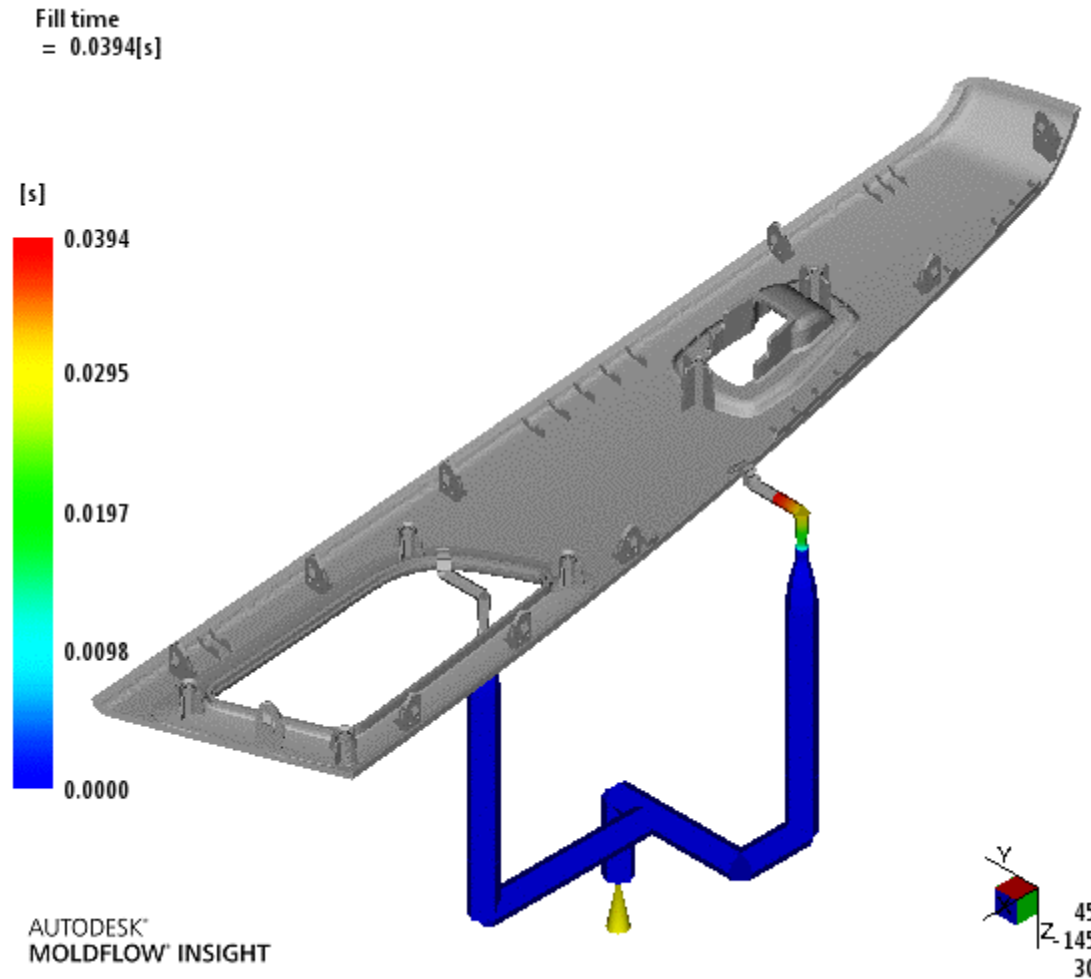

Comments: Animation Is Showing The Flow Path Of Molten Material.

Tools Manufacturing

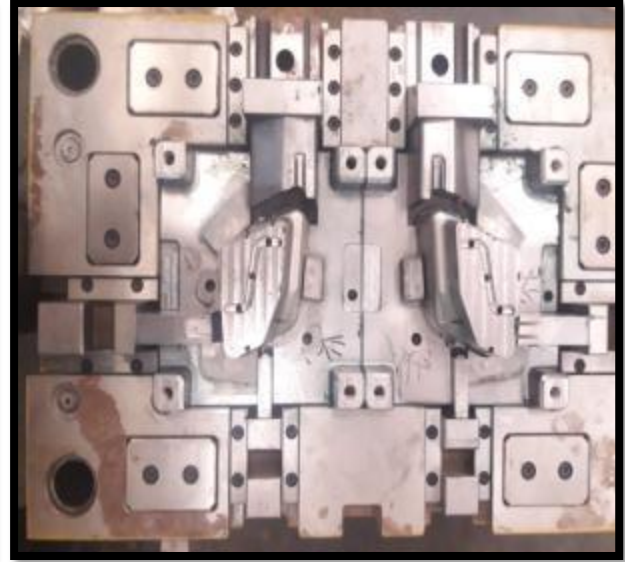
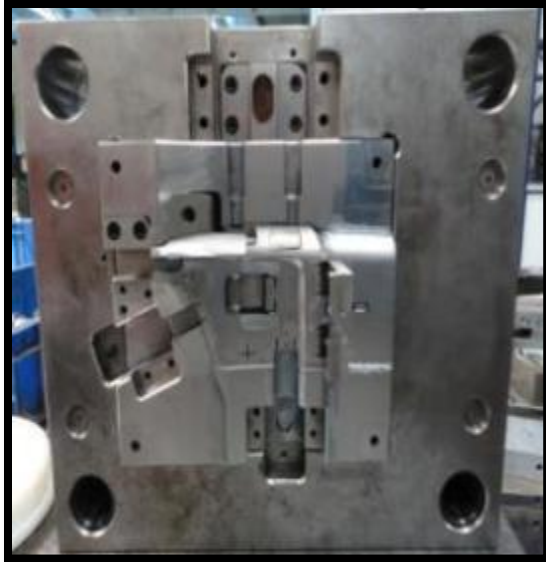

Tools Manufacturing

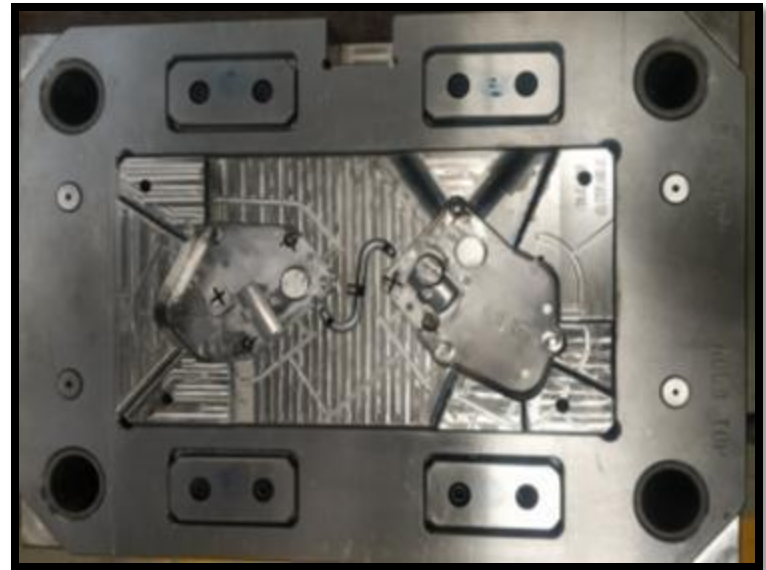
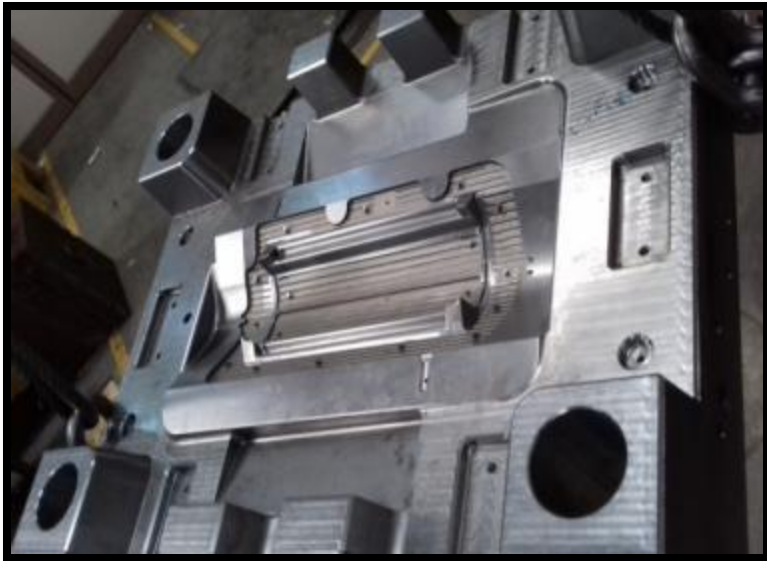
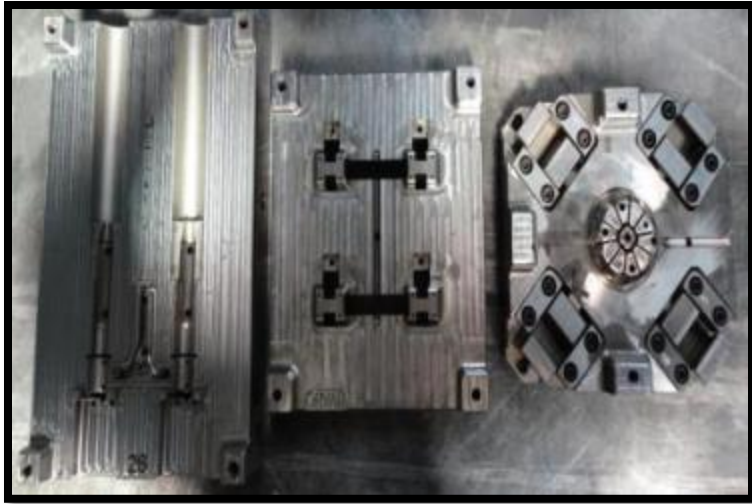

Tools Manufacturing

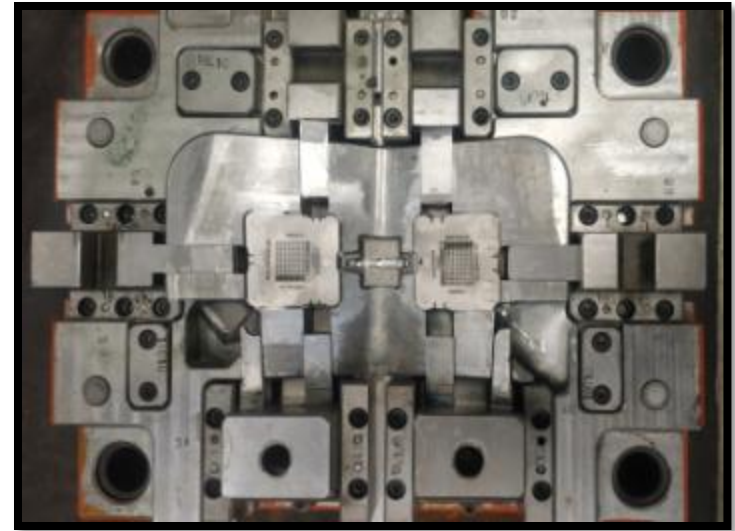

Achievements



Customer –LEAR
Category – Excellent support in
NPD
Year - 2012



Customer – Mahle Behr
Category – Kaizen Award
Year - 2013

Achievements



Customer –LEAR
Category – Excellent support in
NPD
Year - 2013



Customer – Mahle Behr
Category – Excellent in Quality
Year - 2014

Achievements



Customer – Lear
Category – Excellent in Quality
Year - 2014



Customer – Mahle Behr
Category – Excellent support in
NPD
Year - 2015

Achievements



Customer – IAC
Category – Excellent support in
NPD
Year - 2016



Customer – Mahle Behr
Category – Excellent in Quality
Year - 2016

Achievements



Customer – Mahle Behr
Category – Best supplier
Year - 2017



Customer – Mahle Behr
Category – Excellence in Quality
Year - 2019

Achievements



Customer – AITTR
Category – BU Best supplier
Year - 2019

Achievements



Customer – BHTC
Category – KAIZEN
Year - 2021

CONTACT US

Name	E-mail ID	Mobile No.
Mr. David K.	david@divinepune.com	9890360684
Mr. Prem Kumar	production@divinepune.com	9730355789
Mr. Davison.M	npd@divinepune.com	9970323105
Mr. Ragesh.P	toolroom@divinepune.com	7420032266
Mr. Rajesh S.	design@divinepune.com	9823097726
Mr. Milind M.	production@divinepune.com	9049790523
Mrs. Gayatri P.	quality@divinepune.com	7447449163
Mr. Dhanraj	sales@divinepune.com	9561419963
Mr. Lalasaheb P.	store@divinepune.com	9970006665
Mr. Unni Krishnan	development@divinepune.com	9960738929
Mrs. Divya M.	finance@divinepune.com	9773328342
Mrs. Selvi N.	account@divinepne.com	9172278777

